

TP-2M

SPECIFICATIONS & OPERATING INSTRUCTIONS

OPERATING SHUT HEIGHT:	9-3/8" (238.1mm)
MIN. SHUT HEIGHT:	9-1/4" (235.0mm)
UNIT OPEN HEIGHT:	11-13/16" (300.0mm)
MAX. TUBE SIZE:	1.000" round (25.40mm) 7/8" square (22.2mm)

MAX. WALL THICKNESS (MILD STEEL):	.125" (3.18mm)
MIN. DIE CLEARANCE:	.012" (.30mm)

To ORDER, SPECIFY:

- Size of Tube
- Hole Diameter
- Wall Thickness
- Type of Material
- Hole Location

COMPLETE UNIT	COMMON DIMENSIONS	
Part No.	Throat Depth	Shipping Weight
17600M	8"	20 lbs.

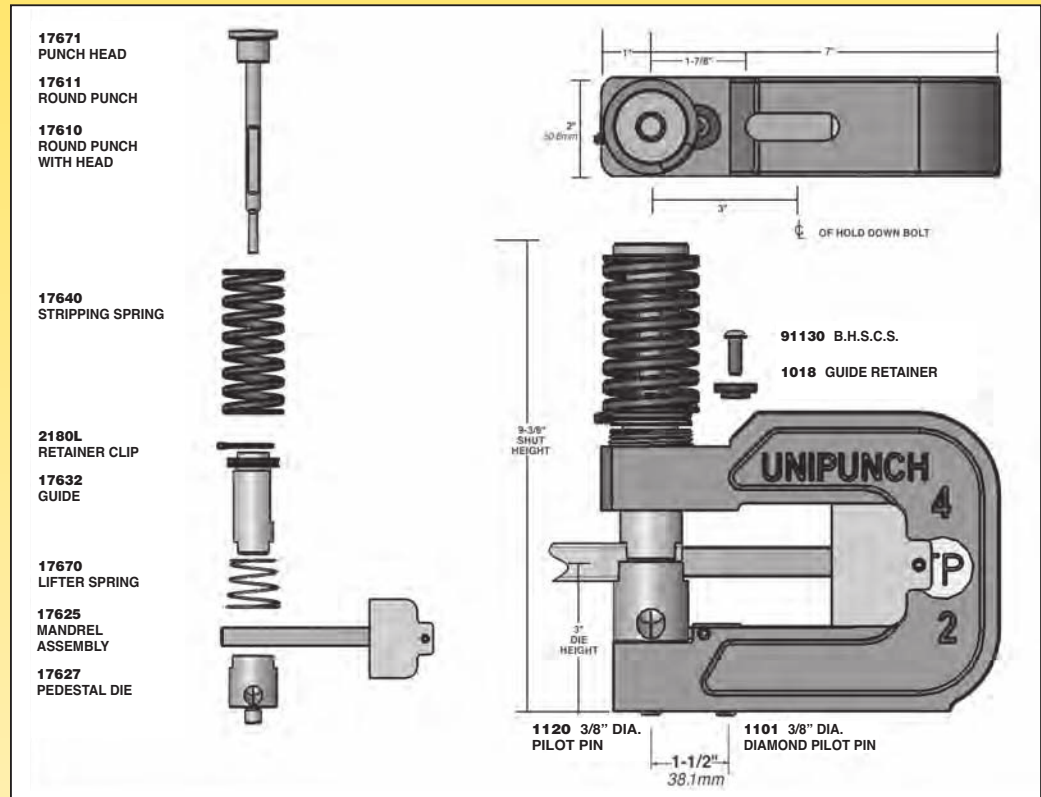

Note: Various throat depths are available. Contact the UniPunch Sales Department with tube specifications and hole location.

TP SERIES